

66 x 36 x 23 3/4

WHIRLPOOL LEFT DRAIN MODEL #W6636ISL

WHIRLPOOL RIGHT DRAIN MODEL #W6636ISR

AIR-WHIRLPOOL LEFT DRAIN MODEL #W31LUX6636ISL

AIR-WHIRLPOOL RIGHT DRAIN MODEL #W31LUX6636ISR

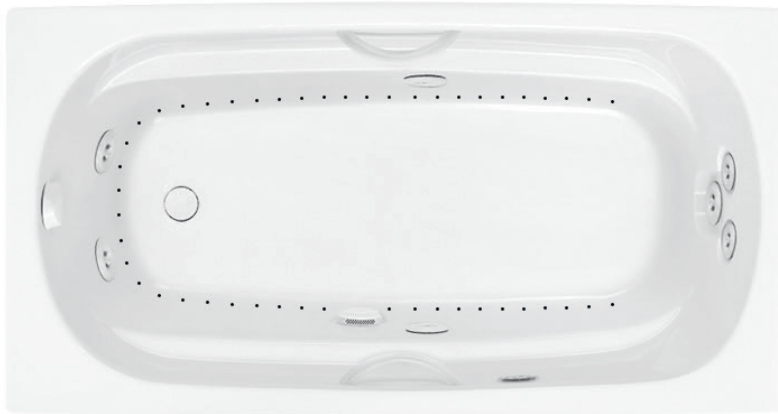

### FEATURES ~

- Integral skirt with removable access panels
- Integral tile flange
- Deep, ergonomic bathing well
- Sculpted armrests
- Bolt-on grab bars (chrome or color matched)
- Slip resistant floor
- Premium cast acrylic surface
- Limited lifetime warranty

### AVAILABLE SYSTEMS

#### WHIRLPOOL

- Electronic control
- 7 hydrotherapy jets
  - 3-jet back, shoulder and neck massage system (dual port, spinning)
  - Leg and foot jets
- Whirlpool pump

#### AIR-WHIRLPOOL COMBINATION

- Whirlpool system, plus:
- Perimeter air system
- Variable speed heated-air blower with purge and dry cycle
- Electronic wave and pulse modes
- 1.5kW inline maintenance heater

# SANTA CRUZ

66 x 36 x 23 3/4 inches

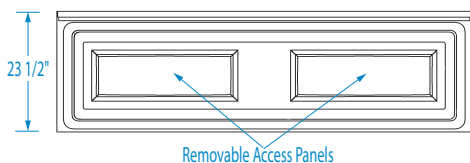
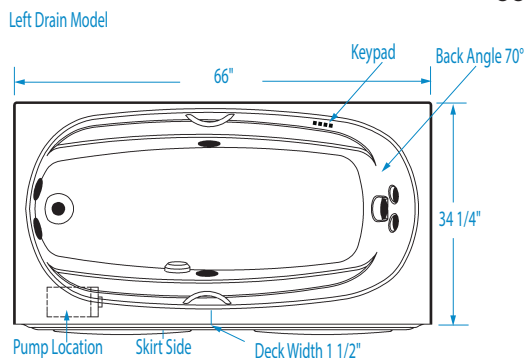
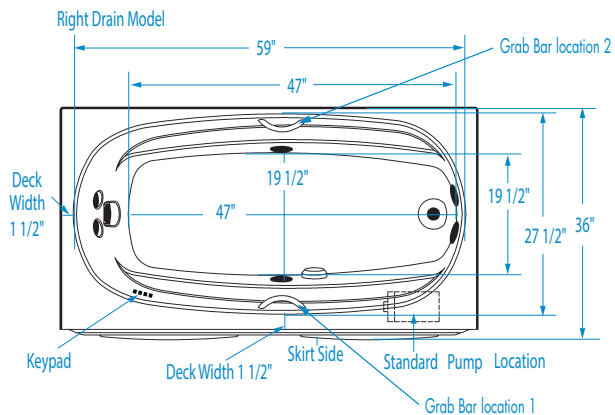

Note: Requires a mortar base. Support Base not included.

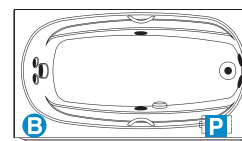
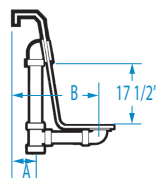

Note: For Air-whirlpool, no alternate pump/blower location available.

Note: Grab Bar option comes with two grab bars.

**FEATURES** lbs (kg) Dimensional Tolerance ± 3/8". Dimensions needed for site preparation should be measured from the unit. Aquatic assumes no responsibility for preparatory work.

Type and Model #	Material	Jets	Pump	Air System	Blower	Heater	Controls	Drain	Pkg. Wt.
Whirlpool #W66361SL/R	Cast Acrylic	7	102 GPM	—	—	1.5 kw Inline (optional)	Electronic	LH or RH	153
Air-Whirlpool #W31LUX66361SL/R	Cast Acrylic	7	102 GPM	Channel	Variable speed	1.5 kw Inline	Electronic	LH or RH	292

## DIMENSIONS inches

Width Overall / Net	Depth Overall / Net	Height Overall / Net	Skirt Height
66	36	23 3/4	22 5/8

## SUMP DATA inches

Capacity to Overflow gal (ltr)	Min. Operating Capacity gal (ltr)	WIDTH @ centerline		DEPTH @ centerline	
		Top	Bottom	Top	Bottom
85	66	59	47	27 1/2	19 1/2

## PLUMBING DIMENSIONS inches

A	B	Drain Diameter / Clearance
1 3/4	10 3/4	

## ELECTRICAL DATA

Component	Specification	Requirement
Pump	9 AMP; 120V	15 AMP; 120V, separate circuit; Class A GFCI
Optional Heater	1.5 kW; 12 AMP; 120V	15 AMP; 120V, separate circuit; Class A GFCI
Blower	1.0 HP; 9.5 AMP; 120V	15 AMP; 120V, separate circuit; Class A GFCI

NOTE:  
1) This whirlpool must be hard wired to the breaker box. Three outlets will be supplied on the air-whirlpool.

- NOTES:  
1) Where applicable, utilize cut-out templates packed with unit for deck cutouts.  
2) 16 x 16 minimum access required at pump/blower location(s).  
3) If a (3T) tiling flange is selected, then the keypad is located opposite of the flange.